

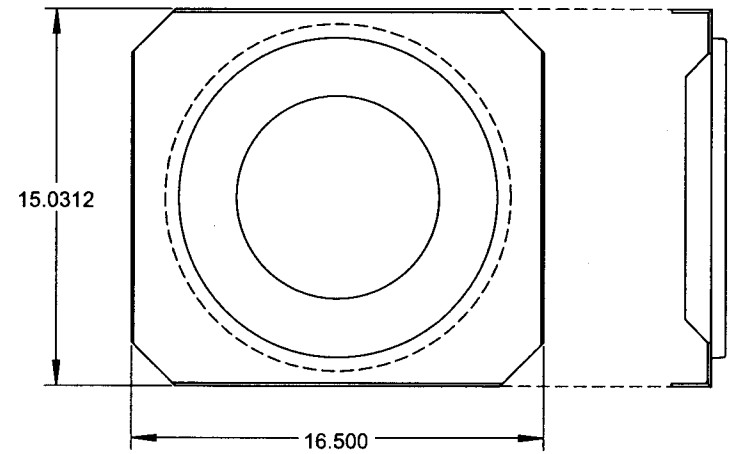

Item Number	Description	Length (L) (Inches)	Media Area (Square Feet)
1282314	AG66-2312-109	26	158
1282335	AG66-2336-109	36	220

NOTES

1. Maximum Temperature: 180 deg. F
2. Top & Bottom End caps:
22 GA Electro Galvanized
Open/Closed
3. Inner & Outer Retainers:
22 GA Electro Galvanized Expanded Metal
72% Open Area
4. Available As Cartridge Only Without Mounting
Flange



MOUNTING FLANGE DETAIL

 ONE SOURCE FOR AIR FILTRATION PRODUCTS	P.O. Box 32578 Louisville, KY 40232 P: 502-969-2304 F: 502-961-0930	TOLERANCES UNLESS OTHERWISE SPECIFIED		DRAWING NAME WHEELABRATOR CARTRIDGE W/ MOUNTING PLATE	
		FRACTIONAL DECIMAL ANGLES	APPROVED BY <i>H. Quinn</i>	SPECIFICATION NO. MKT-B-00317	PAGE 1 OF 1
CONTACT FACTORY TO VERIFY REVISION LEVEL		SCALE NONE	DWG. SIZE A	REVISION A	REVISION DATE 03-06-03
ALL DIMENSIONS IN INCHES		CONFIDENTIAL - DO NOT COPY. THIS MATERIAL IS TRADE SECRET AND PROPRIETARY BEING EXCLUSIVELY OWNED BY AIRGUARD. THE EXPRESSION OF THE INFORMATION CONTAINED HEREIN IS PROTECTED UNDER FEDERAL COPYRIGHT LAWS AND ALL COPYING IS PROHIBITED AND MAY BE SUBJECT TO CRIMINAL PENALTIES.			