

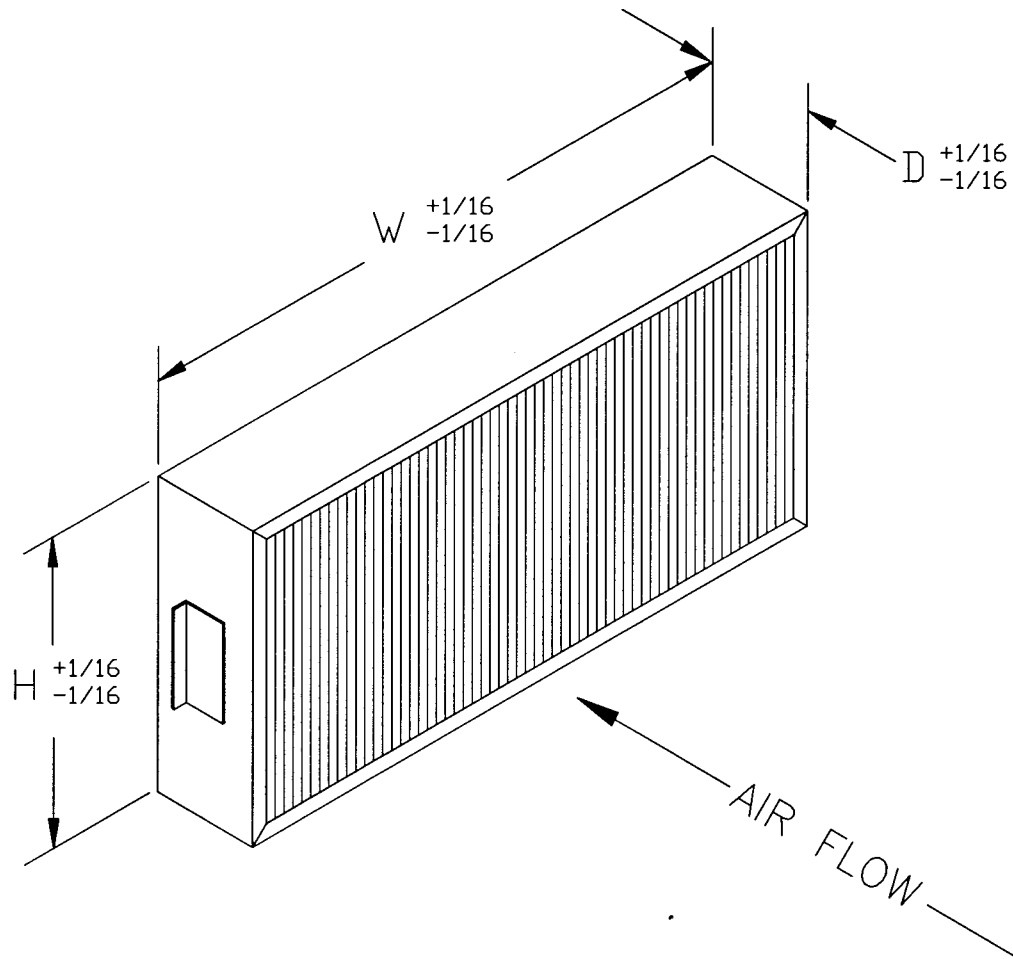

Item Number	Model Number	Actual Size (Inches) H x W x D	Media Area (Square Feet)
1217109	AG11-7109	6-1/2 x 33 x 2-3/16	70



STANDARD CONSTRUCTION
 1. 25 GA Hot Dip Galvanized
 2. Bracket On One Side (Shown)

 ONE SOURCE FOR AIR FILTRATION PRODUCTS	P.O. Box 32578 Louisville, KY 40232 P: 502-969-2304 F: 502-961-0930	TOLERANCES UNLESS OTHERWISE SPECIFIED				DRAWING NAME AG11-7109			
		FRACTIONAL DECIMAL ANGLES		APPROVED BY <i>H. Am</i>		SPECIFICATION NO. MKT-B-00297		PAGE 1 OF 1	
CONTACT FACTORY TO VERIFY REVISION LEVEL		ALL DIMENSIONS IN INCHES		SCALE NONE	DWG. SIZE A	REVISION B	REVISION DATE 03-11-03		
<small>CONFIDENTIAL - DO NOT COPY. THIS MATERIAL IS TRADE SECRET AND PROPRIETARY BEING EXCLUSIVELY OWNED BY AIRGUARD. THE EXPRESSION OF THE INFORMATION CONTAINED HEREIN IS PROTECTED UNDER FEDERAL COPYRIGHT LAWS AND ALL COPYING IS PROHIBITED AND MAY BE SUBJECT TO CRIMINAL PENALTIES.</small>									